

852 Series Power Take-Off Unit

852XGAKP-B6XS

URL:<https://www.sxplc.com/852-series-power-take-off-unit-852xgakp-b6xs>

Product data sheet

Model Number Designator

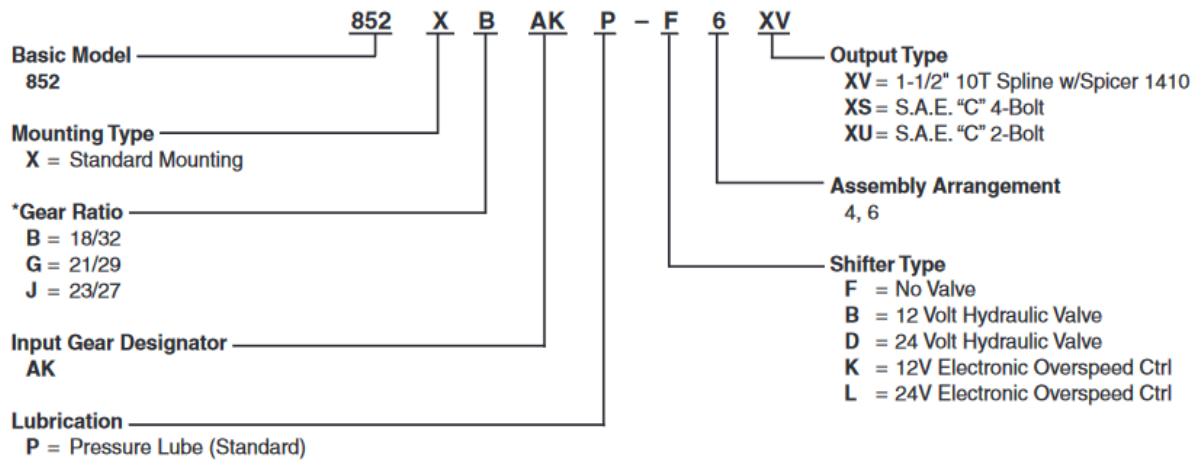

NOTE: *Internal P.T.O. Gears - P.T.O. Ratio Gear/P.T.O. Output Gear

